

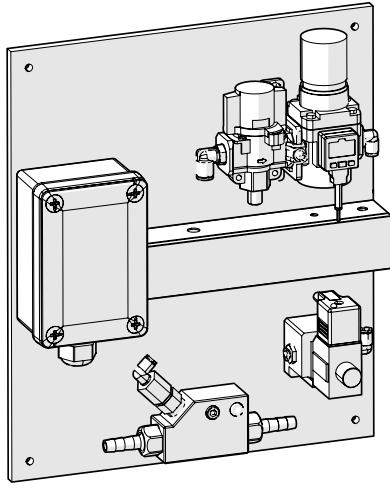

AIR ASSIST MODULE MULTIPLEX ACCESSORY



Description

The Air Assist Module is a versatile accessory compatible with the Multiplex 1 Pro and Multiplex 2 Pro, designed to enhance efficiency by flushing products faster than water alone. After completing dosages, the system performs a water flush, followed by an optional air flush using the module, ensuring quicker and more effective transfer to the washer extractor.

Featuring integrated pressure regulators and easy-to-use controls, the module delivers consistent airflow and reliable performance across applications. Built for industrial environments, it optimizes system efficiency while ensuring precise calibration.

Technical Specifications

		Value
AIR	Working pressure	2.5 bar (max)
	Air intake	10 mm
	Average consumption	700 l/m
	Air entrainment	8 mm
PANELS	Material	PVC
AIR INJECTOR	Body	PVDF
ELECTRO VALVE	Voltage	24 VDC
	Power	120W

Details

Part Code	Description	Width	Height
A500AA	AIR ASSIST PANEL	300 mm	350 mm

Diagram

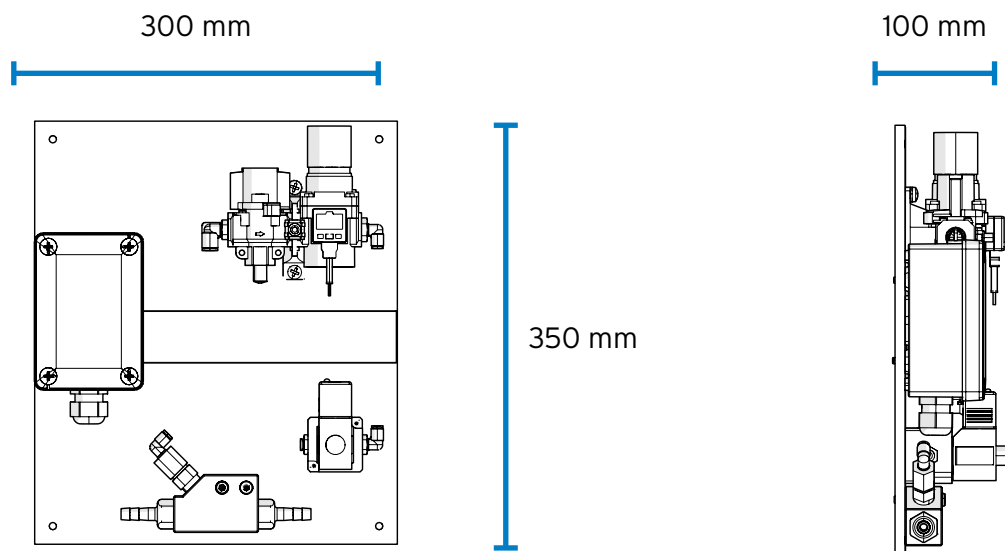

Dimensions (mm)

Width	Height	Depth
300	350	100

Weight

0.5 kg (approx)

Connection

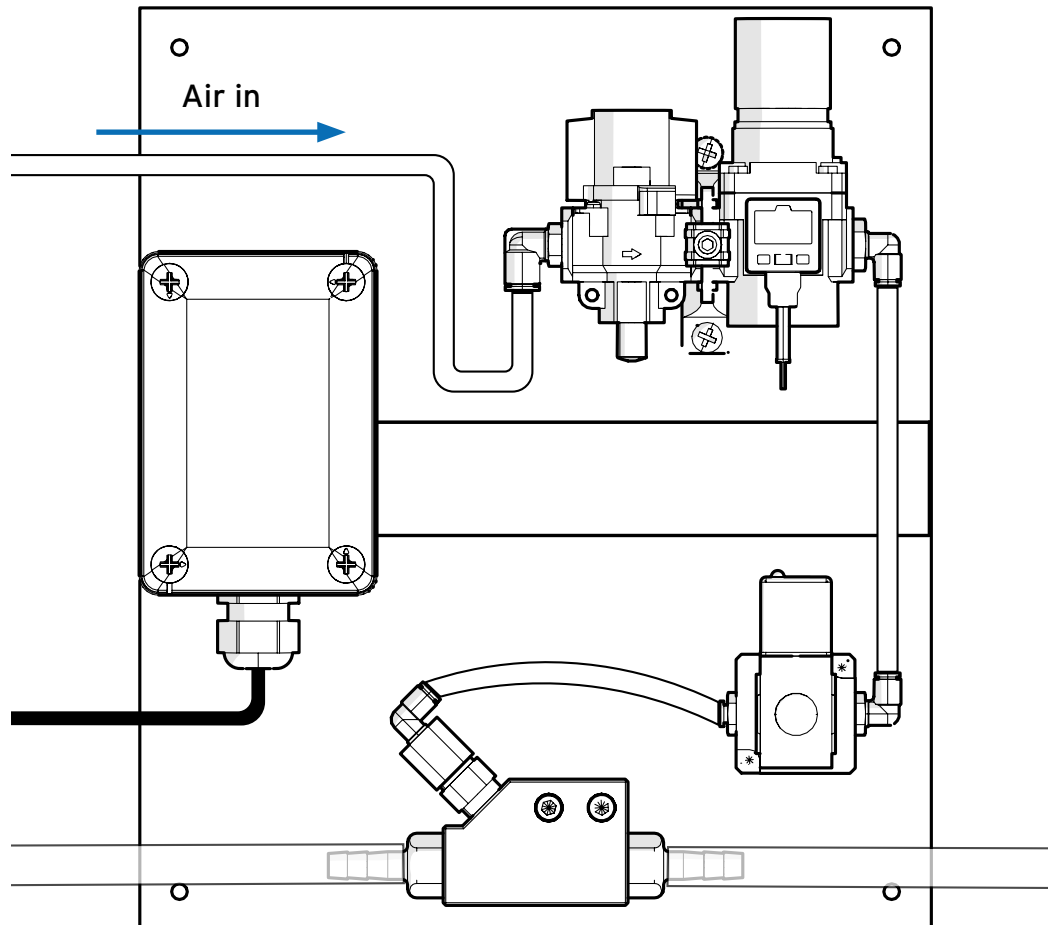

T +44 (0) 1273 513566 E sales@brightwell.co.uk W brightwell.co.uk

Unit 1, Rich Industrial Estate, Avis Way, Newhaven, East Sussex, BN9 0DU, UK

All information in this data sheet is correct at the time of printing and is subject to change without notice.